



ONE RIVER POINT

BY RAFAEL VIÑOLY

WEST TOWER

RESIDENCE F3

LINE 01 ON FLOORS: 10 / 15-17 / 21-23 / 27-29 /

33-34 / 38-40 / 44-46 / 50

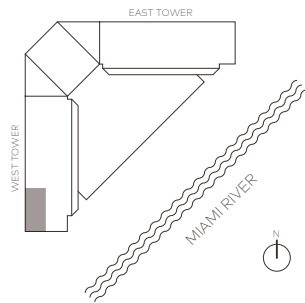

1 Bedroom
1.5 Bathrooms

Total: 1,079ft² / 100m²



For inquiries, please call 305-809-7566 or visit: oneriverpoint.com



This is not intended to be an offer to sell, or solicitation to buy, condominium units to residents of any jurisdiction where such offer or solicitation cannot be made or are otherwise prohibited by law, and your eligibility for purchase will depend upon your state of residency. This offering is made only by the prospectus for the condominium and no statement should be relied upon if not made in the prospectus. The information provided, including pricing, is solely for informational purposes, and is subject to change without notice.

ORAL REPRESENTATIONS CANNOT BE RELIED UPON AS CORRECTLY STATING THE REPRESENTATIONS OF THE DEVELOPER. FOR CORRECT REPRESENTATIONS, MAKE REFERENCE TO THIS BROCHURE AND TO THE DOCUMENTS REQUIRED BY SECTION 718.503, FLORIDA STATUTES, TO BE FURNISHED BY A DEVELOPER TO A BUYER OR LESSEE.

With Respect to NY Purchasers: This advertisement is not an offering. It is a solicitation of interest in the advertised property. No offering of the advertised units can be made and no deposits can be accepted, or reservations, binding or non-binding, can be made until an offering plan is filed with the New York State Department of Law. This advertisement is made pursuant to Cooperative Policy Statement No. 1, issued by the New York State Department of Law. File No.: CP17-0033.

Stated square footages and dimensions are measured to the exterior boundaries of the exterior walls and the centerline of interior demising walls and in fact vary from the square footage and dimensions that would be determined by using the description and definition of the "Unit" set forth in the Declaration (which generally only includes the interior airspace between the perimeter walls and excludes all interior structural components and other common elements). This method is generally used in sales materials and is provided to allow a prospective buyer to compare the Units with units in other condominium projects that utilize the same method. For your reference, the area of the Unit, determined in accordance with these defined unit boundaries, is set forth above and is labeled as square feet. Measurements of rooms set forth on this floor plan are generally taken at the farthest points of each given room (as if the room were a perfect rectangle), without regard for any cutouts or variations. Accordingly, the area of the actual room will typically be smaller than the product obtained by multiplying the stated length and width. All dimensions are estimates which will vary with actual construction, and all floor plans, specifications and other development plans are subject to change and will not necessarily accurately reflect the final plans and specifications for the development. All depictions of appliances, counters, soffits, floor coverings and other matters of detail, including, without limitation, items of finish and decoration, are conceptual only and are not necessarily included in each Unit.

This Condominium is being developed by MIAMI RIVER PROJECT, LLC, a Delaware limited liability company ("Developer"), which has consulted with the various Design Team and Development Team members ("Team Members"). Developer has a limited right to use the trademarked names and logos of the Team Members. Any and all statements, disclosures and/or representations shall be deemed made by Developer and not by any of the Team Members and you agree to look solely to Developer (and not to any Team Members, including, without limitation, Rafael Vinoly Architects or Kar Miami MRP LLC and/or any of their affiliates) with respect to any and all matters relating to the marketing and/or development of the Condominium and with respect to the sales of units in the Condominium.

Plans and elevations are artist's renderings and may contain options which are not standard on all models. All dimensions are approximate and subject to change, at Miami River Project, LLC, a Delaware limited liability company's discretion and should not be relied upon. Additionally, all fixtures and items of finish and decoration depicted are for display only and are not to be included with the unit. Consult the sales office for a description of those features which are to be included in the units.

The items depicted and described herein are intended to illustrate the type of fixtures and/or items of finish that are anticipated to be used in various areas within the development. Developer may, in its sole discretion, make changes and/or elect to make omissions. Additionally, Developer has the right to substitute or change materials and/or colors, equipment, appliances, fixtures, finishes landscaping, lighting and all other matters of construction or detail. Even if no changes are made, certain items are subject to size and color variations, grain and quality variations, and may vary in accordance with price, availability and changes by manufacturer from those specified. Certain colors described and/or as shown herein, including, but not limited to, stone, marble, granite, cabinetry, carpeting and wood stain, will weather and fade and may not be duplicated precisely. All exposed wood, tile and stone surfaces are subject to variations in color, unevenness, and non-structural changes and cracks, and the Developer will not be responsible for any repair, replacement, or damages due to any of such causes.

